

Operation, Installation & Maintenance Instruction Guide

Please complete the information below and leave this brochure with your customer after installation is complete.

IMPORTANT WARRANTY AND MAINTENANCE INFORMATION ON THE REVERSE SIDE.

INSTALLED BY:

Contractor Name & Phone No.

PRODUCT INFORMATION:

Model 2300

MODEL:

FILTER SIZE:

INSTALLATION DATE:

DEALER INSTALLATION GUIDE

Please read carefully BEFORE INSTALLING the Model 2300 Electronic Air Cleaner.

IMPORTANT!

This unit is designed to operate from a SUPPLY OF 24 VOLTS AC AT 2VA

DO NOT CONNECT TO 110 VAC POWER!

Connecting the Model 2300 to a higher voltage than specified may cause damage and/or failure of equipment. 110 TO 24 VOLT adapters or transformers are available through your local wholesaler.

ELECTRICAL HOOKUP

Most forced air heating or cooling systems, or heat pumps, have an internal 24 V AC power source to which the **ELECTRONIC AIR CLEANER** can be safely connected without overloading other circuits.

CHECK if the system is protected by a low voltage fuse and make sure connections are made on the **FUSED SIDE**. If no fuse is present, a low-voltage in line fuse should be installed.

BEFORE connecting the **AIR CLEANER** to this power source, **POSITIVELY** identify that this is a 24 V (max 30 V) AC source, and not some other voltage. This is usually best

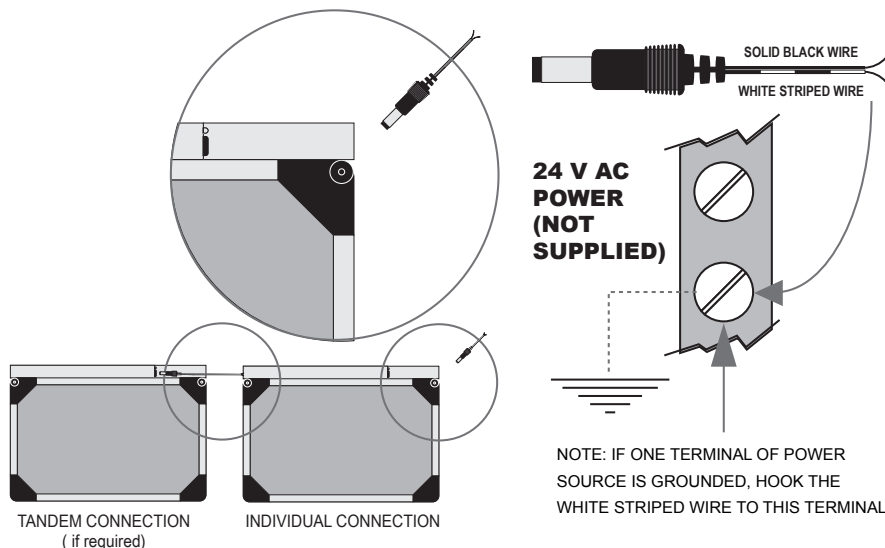

Maintenance and Warranty Instructions

OPERATION

While the electronic air cleaner is operating, the power supply light will be ON.

If the light does not come on when the power is supplied to the air cleaner, refer to the troubleshooting section below.

The electronic air cleaner uses little power (less than 2 watts) and is on continuously. The system fan can be operated continuously for increased air circulation through the air cleaner.

TROUBLESHOOTING

If the air cleaner does not seem to be functioning, check the following:

1. Check that the power supply light is "ON". If the light is "OFF", check the power supply and wiring connections.
2. If the power is not being supplied to the power head, it may need to be replaced. Contact your dealer / contractor or call customer service at Ecoairflow.

When ordering, please let us know the filter model number and filter size.

CONTACTING ECOAIRFLOW

CUSTOMER SERVICE

If you require assistance with your product or wish to order replacement pads for your filter, you can call the contractor that installed your filter or contact ECOairflow directly.

PRODUCT WARRANTY

Your ECOairflow filter is covered by a five-year limited warranty. Please read the warranty conditions outlined on the reverse side of this warranty card.

MAINTENANCE

We recommend that the filter be checked and cleaned once per month.

Before servicing the filter, first disconnect the power supply, then remove the filter from the designated slot.

Remove any build up on the outside screen with either a soft cloth or the soft brush attachment of a vacuum.

Once the screen has been cleaned, hold the filter up to a light. If the black strings can be seen, the filter pads DO NOT need to be replaced. If the black strings cannot be seen, replace the pads.

For optimum effectiveness, we recommend that you replace your filter pads at a minimum every three months.

To order replacement filter pads, call your local contractor or contact ECOairflow at:

Tel: 1.877.347.3569
Fax: 1.866.367.8826
Email: customerservice@ecoairflow.com
Web Site: www.ecoairflow.com

WARRANTY CLAIMS

If you have a warranty claim, please contact ECOairflow's Customer Service to obtain an RMA (Return Merchandise Authorization) number. Please read the Warranty Conditions on the reverse side of this page.

When you call, we will need the model, size and manufacture date of your filter. This information is contained on a label located on the top of the filter.

ECOairflow

1885 Clements Road,
Unit 210
Pickering, ON L1W 3V4

Tel: 1.877.347.3569
Fax: 1.866.367.8826
Email: customerservice@ecoairflow.com
Web Site: www.ecoairflow.com

ECOairflow LIMITED FIVE-YEAR WARRANTY

If you experience a problem with your product, do not attempt to repair the product yourself. Doing so may void the warranty and could cause damage or personal injury.

ECOairflow warrants this product to be free from defects in the workmanship or materials, under normal use and service, for a period of five years from date of purchase by the consumer. If, at any time during the warranty period, the product is defective or malfunctions, ECOairflow shall repair or replace it (at Ecoairflow's option) within a reasonable period of time.

This warranty does not cover removal or reinstallation labor costs or other expenses; it also does not cover any shipping costs.

This warranty shall not apply if the defect/malfunction was caused by:

- (1) damage resulting from abusive or unreasonable use;
- (2) neglect or failure to clean the unit;
- (3) use not in conformity with the printed directions;
- (4) supplemental changes; or
- (5) flood, fire or acts of God.

Damages that are the result of normal wear and tear will not be considered manufacturing defects under this warranty. This warranty applies only to the original purchaser of this product.

ECOairflow's sole responsibility shall be to repair or replace the product within the terms stated above. ECOAIRFLOW SHALL NOT BE LIABLE FOR ANY LOSS OR DAMAGE OF ANY KIND, INCLUDING ANY INCIDENTAL OR CONSEQUENTIAL DAMAGES RESULTING, DIRECTLY OR INDIRECTLY, FROM ANY BREACH OF ANY WARRANTY, EXPRESS OR IMPLIED, OR ANY OTHER FAILURE OF THIS PRODUCT. Some jurisdictions do not allow the exclusion or limitation of incidental or consequential damages, so this limitation may not apply to you.

THE WARRANTIES SET FORTH HEREIN ARE EXCLUSIVE, AND ECOAIRFLOW EXPRESSLY DISCLAIMS ALL OTHER WARRANTIES, WHETHER WRITTEN, ORAL, IMPLIED OR STATUTORY, INCLUDING BUT NOT LIMITED TO ANY WARRANTIES OF MERCHANTABILITY, WORKMANSHIP, OR FITNESS FOR A PARTICULAR PURPOSE.

This warranty gives you specific legal rights, and you may have other rights that vary from jurisdiction to jurisdiction.

If the product is defective or you have any questions regarding this warranty, please contact the ECOairflow customer service department.

Model 2300

Product Warranty Registration

WARRANTY REGISTRATION

Register your warranty on-line www.ecoairflow.com under WARRANTY or complete mail or fax the following form to: ECOairflow

FILTER SIZE (DIMENSIONS) _____

NAME: _____

ADDRESS: _____

TELEPHONE: _____

EMAIL: _____

INSTALLED BY: _____
(contractor name & telephone)

DATE INSTALLED: MONTH _____ DAY _____ YEAR _____